

Use & Care Guide
Manual de Uso y Cuidado



System tested and certified by NSF International against NSF/ANSI Standard 42 for the reduction of chlorine taste and odor, and Standard 44 for hardness reduction, efficiency and the reduction of barium and radium 226/228, and certified to NSF/ANSI/CAN Standard 372.

Este sistema ha sido probado y certificado por NSF International según la norma NSF/ANSI 42 para la reducción del sabor y el olor a cloro, y la norma 44 para la reducción de la dureza, eficiencia y la reducción del bario y del radio 226/228, y certificado según la norma NSF/ANSI/CAN 372.



System tested and certified by the Water Quality Association against CSA B483.1.

Este sistema ha sido probado y certificado por la Water Quality Association según la norma CSA B483.1.

Kenmore Elite® Hybrid Water Softener

A water softener and a whole home filter in one

Ablandador Híbrido de Agua

Un ablandador de agua con filtro integrado para toda la casa

Model / Modelo: 625.385200

Kenmore and the Kenmore logo are registered trademarks of Transform SR Brands LLC, and are used under license by Water Channel Partners, Eagan, Minnesota, 55121, USA.

Customer Assistance / Asistencia al Cliente
www.kenmorewatersolutions.com

Water Channel Partners
2805 Dodd Road, Suite 300
Eagan, MN 55121



TABLE OF CONTENTS

	Page
Specifications & Performance Claims	3-4
Before You Start	4
Inspect Shipment	5
Water Conditioning Information	5
Installation Requirements	6-7
Installation Instructions	8-11
Programming the Water Softener	12-13
Controller Features	14-17
Routine Maintenance	18-19
Troubleshooting	20-22
Wiring Schematic	23
Exploded View & Parts List	24-27
Warranty	28

Dimensions

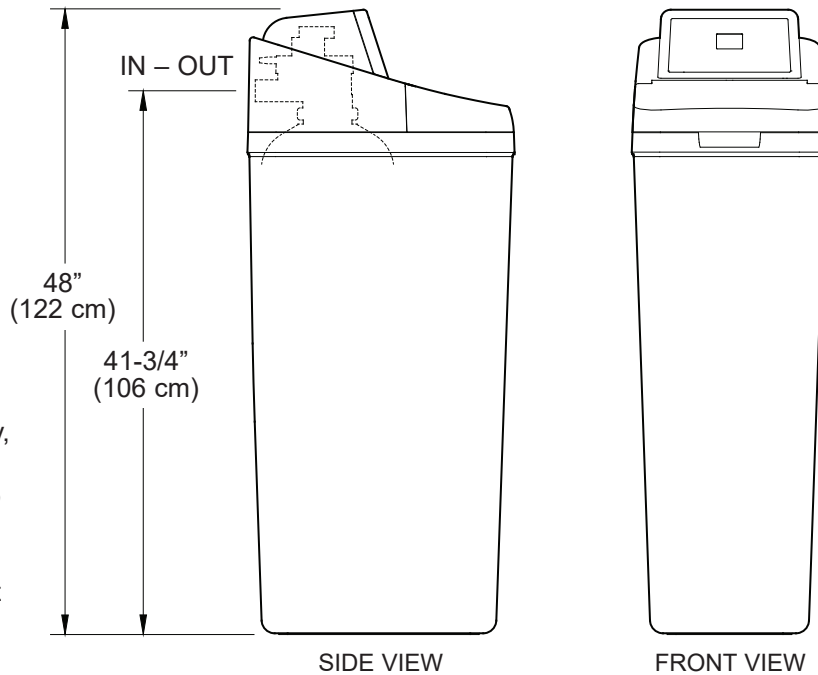
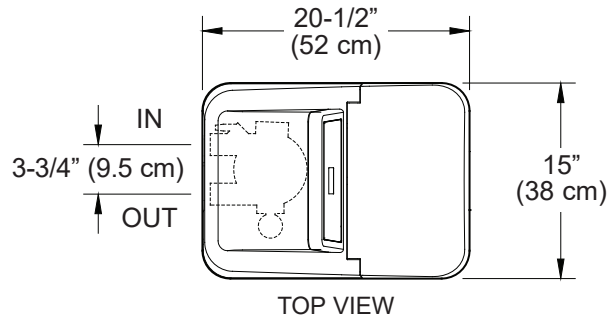

NOTE: Due to variances in production and assembly, the water softener valve height may vary by up to 1/2", and may not match previously installed systems. This will not affect system performance.

FIG. 1

Specifications & Performance Claims

This model is efficiency rated. The efficiency rating is valid only at the minimum salt dose and maximum service flow rate. This system has a demand initiated regeneration (D.I.R.) feature that complies with specific performance specifications intended to minimize the amount of regenerant brine and water used in its operation.

This water treatment system has a rated softener efficiency of not less than 3,350 grains of total hardness exchange per pound of salt (based on sodium chloride) and shall not deliver more salt than its listed rating or be operated at a sustained maximum service flow rate greater than its listed rating. This system has been proven to deliver soft water for at least ten continuous minutes at the rated service flow rate. The rated salt efficiency is measured by laboratory tests described in NSF/ANSI Standard 44. These tests represent the maximum possible efficiency that the system can achieve. Operational efficiency is the actual efficiency after the system has been installed. It is typically less than the rated efficiency, due to individual application factors including water hardness, water usage, and other contaminants that reduce a softener's capacity.

While testing was performed under standard laboratory conditions, actual performance of the system may vary based on local water conditions. This system has been tested according to NSF/ANSI Standard 42 for the reduction of chlorine taste and odor. The concentration of the indicated substance in water entering the system was reduced to a concentration less than or equal to the permissible limit for water leaving the system, as specified in NSF/ANSI Standard 42.

SPECIFICATIONS	
Model 625.385200	
Model Code	520P
Rated Softening Capacity (Grains @ Salt Dose)	11,000 @ 2.6 lbs. 24,700 @ 7.8 lbs. 31,100 @ 13.4 lbs.
Rated Efficiency (Grains/Pound of Salt @ Minimum Salt Dose)	4,230 @ 2.6 lbs.
Water Used During Regeneration @ Minimum Salt Dose	5.0 gal. / 1,000 grains
Total Water Used Per Regeneration @ Maximum Salt Dose	54.7 gallons
Rated Service Flow Rate	8.0 gpm
Amount of High Capacity Ion Exchange Resin	0.98 cu. ft.
Pressure Drop at Rated Service Flow	8.4 psig
Intermittent Flow Rate @ 15 psi*	13.7 gpm
Water Supply Max. Hardness	100 gpg
Water Supply Max. Clear Water Iron	3 ppm**
Water Supply Pressure Limits (minimum / maximum)	20 - 125 psi (137.9 - 861.8 kPa)***
Water Temperature Limits (minimum / maximum)	40 - 120 °F (5 - 49 °C)
Minimum Water Supply Flow Rate	3 gpm (11.4 lpm)
Maximum Drain Flow Rate	2.0 gpm (7.6 lpm)
Rated Capacity at Chlorine Concentration**** of:	0.50 ppm 2,280,000 gal. (8,630,000 liters)§ 0.75 ppm 1,520,000 gal. (5,750,000 liters)§ 1.0 ppm 1,140,000 gal. (4,310,000 liters)§ 1.5 ppm 760,000 gal. (2,870,000 liters)§ 2.0 ppm 570,000 gal. (2,150,000 liters)

*Intermittent flow rate does not represent the maximum service flow rate used for determining the conditioner's rated capacity and efficiency. Continuous operation at flow rates greater than the service flow rate may affect capacity and efficiency performance.

**Capacity to reduce clear water iron is substantiated by laboratory test data. State of Wisconsin requires additional treatment if water supply contains clear water iron exceeding 5 ppm.

***Canada working pressure limits: 1.4 - 7.0 kg/cm².

****Typical residential chlorine concentration is 0.5 to 1.0 ppm.

§ From independent laboratory test data.

This system conforms to NSF/ANSI Standards 42 & 44 for the specific performance claims as verified and substantiated by test data.

continued on next page

Specifications & Performance Claims

continued from previous page

Variable Salt Dose: The salt dose is selected by the electronic controls at regeneration time based on the amount needed.

PERFORMANCE CLAIMS		
Contaminant	Influent Challenge Level	Maximum Allowable Product Water Level
Barium	10 ±10% mg/L	2.0 mg/L
Radium 226/228	25 pCi/L	5 pCi/L
Substance	Influent Challenge Level	Reduction Requirement
Chlorine	2.0 ±10% mg/L	50%

Before You Start

- The water softener requires a minimum water flow of 3 gallons per minute at the inlet. Maximum allowable inlet water pressure is 125 psi. If daytime pressure is over 80 psi, nighttime pressure may exceed the maximum. Use a pressure reducing valve if necessary (Adding a pressure reducing valve may reduce the flow). Failure to use a pressure reducing valve may cause damage to the system, resulting in flooding and damage to property. If your home is equipped with a back flow preventer, an expansion tank must be installed in accordance with local codes and laws.
- The water softener works on 24V DC electrical power, supplied by a direct plug-in power supply (included). Be sure to use the included power supply and plug it into a nominal 120V, 60 Hz household outlet that is in a dry location only, grounded and properly protected by an overcurrent device such as a circuit breaker or fuse.
- Do not use this system to treat water that is microbiologically unsafe or of unknown quality without adequate disinfection upstream or downstream of the system.
- If the system is being used to reduce barium and/or radium 226 and 228, please verify softener performance annually by having your treated water supply tested for water hardness at a local water testing laboratory, or by contacting Legend Technical Services, an independent laboratory, at 1-800-949-8220.



European Directive 2002/96/EC requires all electrical and electronic equipment to be disposed of according to Waste Electrical and Electronic Equipment (WEEE) requirements. This directive or similar laws are in place nationally and can vary from region to region. Please refer to your state and local laws for proper disposal of this equipment.

Questions? Visit www.kenmorewatersolutions.com or call 1-800-695-2761.

Inspect Shipment

The parts required to assemble and install the unit are included in a bag. Thoroughly check the water softener for possible shipping damage and parts loss. Also inspect and note any damage to the shipping carton.

Remove and discard (or recycle) all packing materials. To avoid loss of small parts, we suggest you keep the small parts in the parts bag until you are ready to use them.

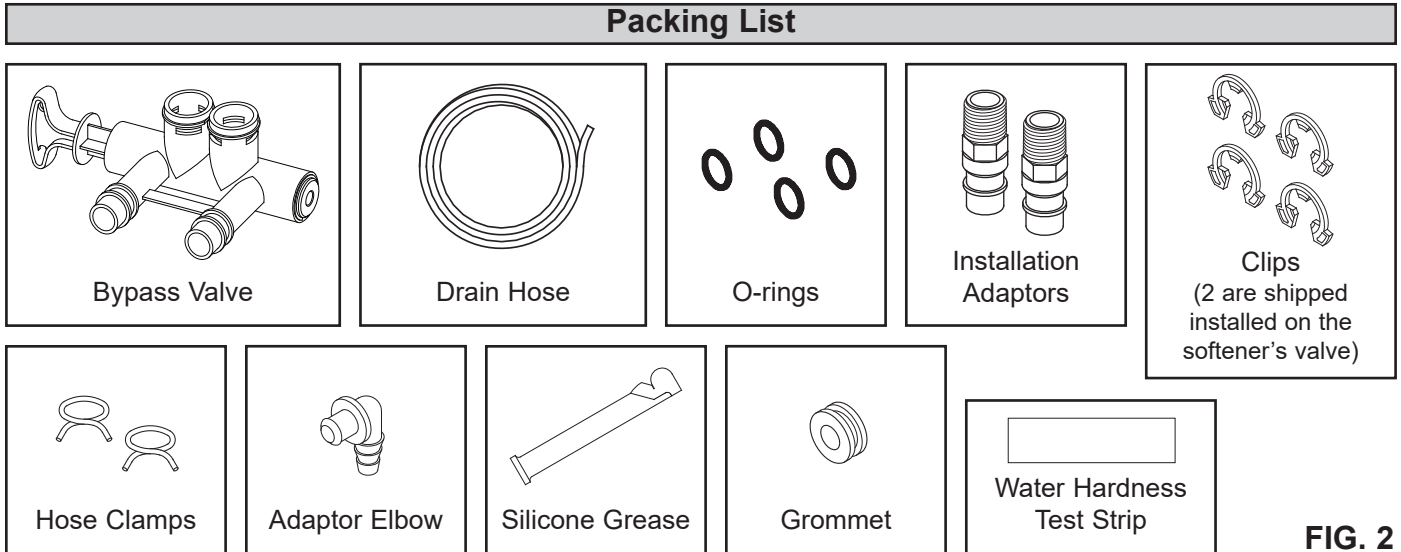

FIG. 2

Water Conditioning Information

IRON

Iron in water can cause stains on clothing and plumbing fixtures. It can negatively affect the taste of food, drinking water, and other beverages. Iron in water is measured in parts per million (ppm). The total* ppm of iron, and type or types*, is determined by chemical analysis. Four different types of iron in water are:

- Ferrous (clear water) iron
- Ferric (red water) iron
- Bacterial and organically bound iron
- Colloidal and inorganically bound iron (ferrous or ferric)

Ferrous (clear water) iron is soluble and dissolves in water. This water softener will reduce moderate amounts of this type of iron (see specifications).**

Ferrous (clear water) iron is usually detected by taking a sample of water in a clear bottle or glass.

Immediately after taking, the sample is clear. As the water sample stands, it gradually clouds and turns slightly yellow or brown as air oxidizes the iron. This usually occurs in 15 to 30 minutes.

When using the softener to reduce Ferrous (clear water) iron, add 5 grains to the hardness setting for every 1 ppm of Ferrous (clear water) iron. See "Set Water Hardness Number" section.

Ferric (red water), and bacterial and organically bound irons are insoluble. This water softener will not remove ferric or bacterial iron. This iron is visible

immediately when drawn from a faucet because it has oxidized before reaching the home. It appears as small cloudy yellow, orange, or reddish suspended particles. After the water stands for a period of time, the particles settle to the bottom of the container. Generally these irons are removed from water by filtration. Chlorination is also recommended for bacterial iron.

Colloidal and inorganically bound iron is of ferric or ferrous form that will not filter or exchange out of water. This water softener will not remove colloidal iron. In some instances, treatment may improve colloidal iron water. Colloidal iron water usually has a yellow appearance when drawn. After standing for several hours, the color persists and the iron does not settle, but remains suspended in the water.

SEDIMENT

Sediment is fine, foreign material particles suspended in water. This water softener will not remove sediment. This material is most often clay or silt. Extreme amounts of sediment may give the water a cloudy appearance. A sediment filter installed upstream of the water softener normally corrects this situation.

* Water may contain one or more of the four types of iron and any combination of these. Total iron is the sum of the contents.

** Capacity to reduce clear water iron is substantiated by laboratory test data.

Installation Requirements

LOCATION REQUIREMENTS

Consider all of the following when selecting an installation location for the water softener.

- Do not locate the water softener where freezing temperatures occur. Do not attempt to treat water over 120°F. Freezing temperatures or hot water damage voids the warranty.
- To condition all water in the home, install the water softener close to the water supply inlet, and upstream of all other plumbing connections, except outside water pipes. Outside faucets should remain on hard water to avoid wasting conditioned water and salt.
- A nearby drain is needed to carry away regeneration discharge (drain) water. Use a floor drain, laundry tub, sump, standpipe, or other options (check your local codes). See "Air Gap Requirements" and "Valve Drain Requirements" sections.
- The water softener works on 24V DC electrical power, supplied by a direct plug-in power supply (included). Provide nearby a 120V, 60Hz electrical outlet in accordance with NEC and local codes.
- Always install the water softener between the water inlet and water heater. Any other installed water conditioning equipment should be installed between the water inlet and water softener (See Figure 4 below).
- Avoid installing in direct sunlight. Excessive sun heat may cause distortion or other damage to non-metallic parts.

PLUMBING CODES

All plumbing must be completed in accordance with national, state and local plumbing codes.

In the state of Massachusetts: The Commonwealth of Massachusetts plumbing code 248-CMR shall be adhered to. A licensed plumber shall be used for this installation.

AIR GAP REQUIREMENTS

A drain is needed for the water discharged from the valve during the softener's regeneration cycle (See Figure 3). A floor drain, close to the water softener, is preferred. A laundry tub, standpipe, etc. are other drain options. Secure valve drain hose in place. Leave an air gap of 1-1/2" between the end of the hose and the drain. This gap is needed to prevent backflow of sewer water into the water softener. Do not put the end of the drain hose into the drain.

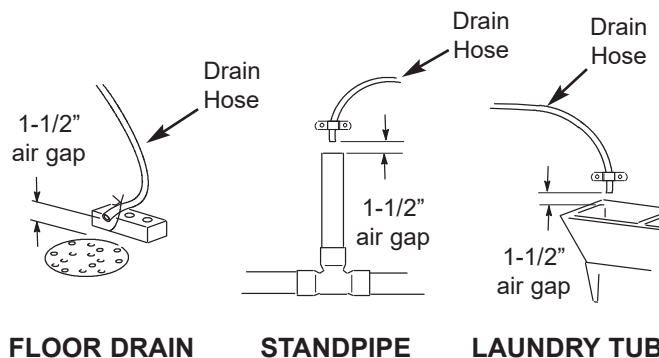

FIG. 3

THE PROPER ORDER TO INSTALL WATER TREATMENT EQUIPMENT

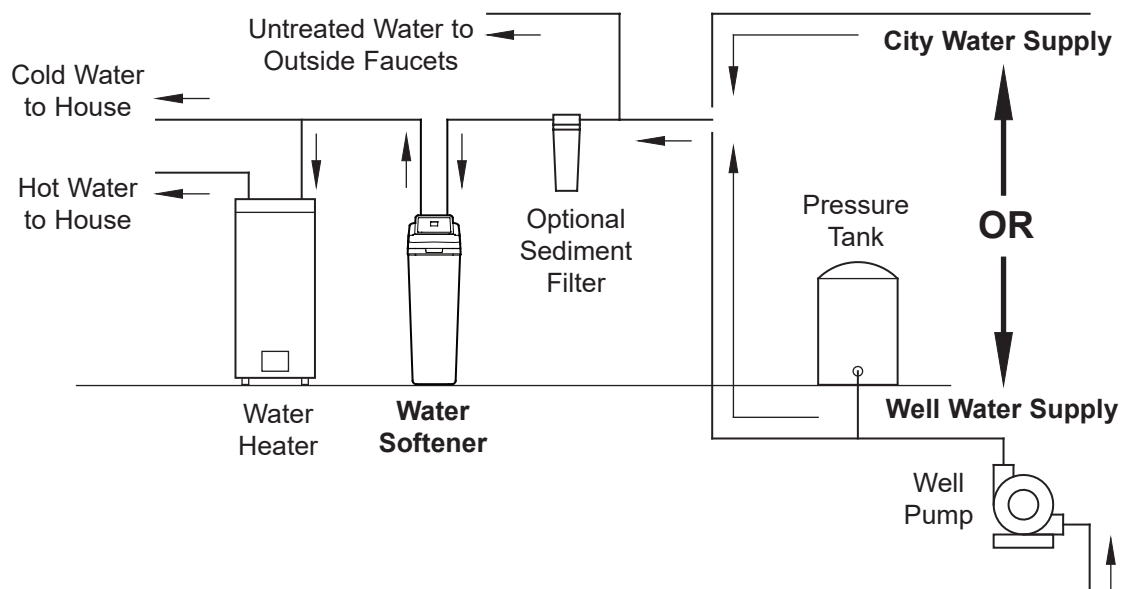

FIG. 4

Installation Requirements

VALVE DRAIN REQUIREMENTS

Using the flexible drain hose (included), measure and cut to the length needed. Flexible drain hose is not allowed in all localities (check your plumbing codes). If local codes do not allow use of a flexible drain hose, a rigid valve drain run must be used. Purchase a compression fitting (1/4 NPT x 1/2 in. minimum tube) and 1/2" tubing from your local hardware store. Plumb a rigid drain as needed (See Figure 6).

NOTE: Avoid drain hose runs longer than 30 feet. Avoid elevating the hose more than 8 feet above the floor. Make the valve drain line as short and direct as possible.

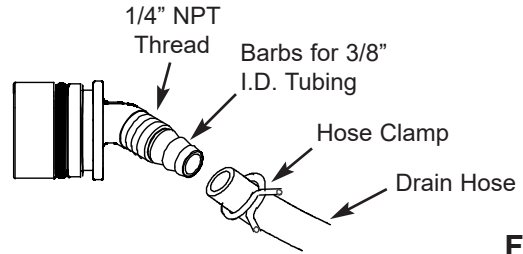

FIG. 5

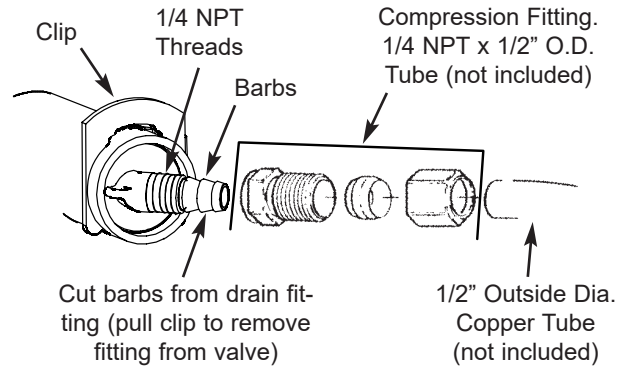

FIG. 6

INLET / OUTLET PLUMBING OPTIONS

Always install either a single bypass valve (provided), as shown in Figure 7, or, if desired, parts for a 3 valve bypass system (not included) can be purchased and assembled, as shown in Figure 8. Bypass valves allow you to turn off water to the softener for maintenance if needed, but still have water in house pipes.

Use:

- Copper pipe
- Threaded pipe
- PEX (Crosslinked Polyethylene) pipe
- CPVC plastic pipe
- Other pipe approved for use with potable water

IMPORTANT: Do not solder with plumbing attached to installation adaptors and single bypass valve. Soldering heat will damage the adaptors and valve.

SINGLE BYPASS VALVE

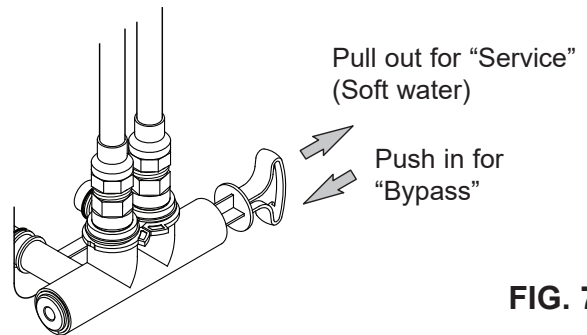

FIG. 7

3 VALVE BYPASS

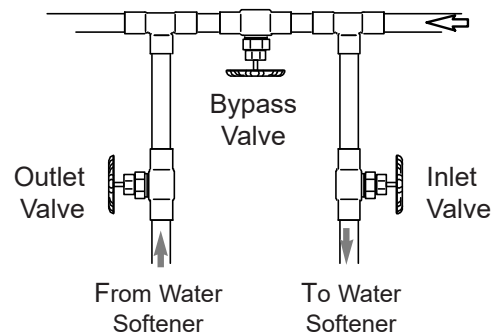

FIG. 8

Installation Instructions

TYPICAL INSTALLATION

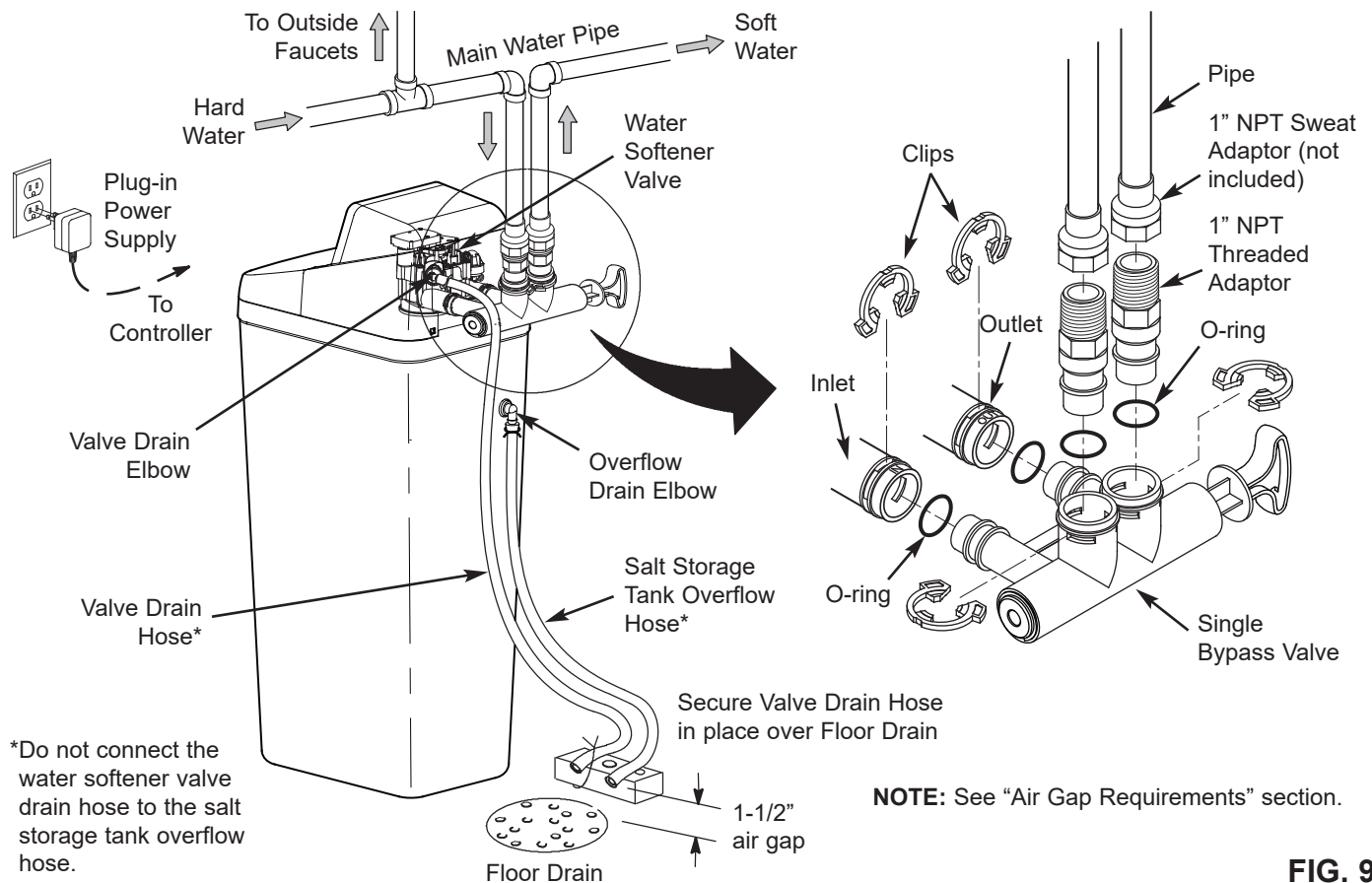

FIG. 9

TURN OFF WATER SUPPLY

1. Close the main water supply valve, located near the well pump or water meter.
2. Shut off the electric or fuel supply to the water heater.
3. Open all faucets to drain all water from house pipes.

NOTE: Be sure not to drain water from the water heater, as damage to the water heater elements could result.

ASSEMBLY

1. Kenmore® models are factory assembled. During installation, unsnap and remove the top cover, together with the salt lid (See Figure 11), to expose the softener valve assembly. Set them aside to prevent damage.
2. Install the brine tank overflow grommet and elbow into the 13/16" diameter hole in the back of the salt storage tank wall (See Figure 11).

MOVE THE UNIT INTO PLACE

1. Move the water softener into the desired location. Set it on a solid, level surface.

IMPORTANT: Do not place shims directly under the salt storage tank to level the softener. The weight of the tank, when full of water and salt, may cause the tank to fracture at the shim.

2. Visually check and remove any debris from the water softener valve inlet and outlet ports.
3. Make sure the turbine assembly spins freely in the "out" port of the valve (See Figure 10).
4. If not already done, put a light coating of silicone grease on the single bypass valve o-rings.
5. Push the single bypass valve into the softener valve as far as it will go. Snap the two large holding clips into place, from the top down as shown in Figures 12 & 13.

IMPORTANT: Be sure the clips snap firmly into place so the single bypass valve will not pull out.

Installation Instructions

COMPLETE INLET AND OUTLET PLUMBING

Measure, cut, and loosely assemble pipe and fittings from the main water pipe to the inlet and outlet ports of the water softener valve. Be sure to keep fittings fully together, and pipes squared and straight.

Be sure hard water supply pipe goes to the water softener valve inlet side.

NOTE: Inlet and outlet are marked on the water softener valve. Trace the water flow direction to be sure hard water is to inlet.

IMPORTANT: Be sure to fit, align and support all plumbing to prevent putting stress on the water softener valve inlet and outlet. Undue stress from misaligned or unsupported plumbing may cause damage to the system.

Complete the inlet and outlet plumbing for the type of pipes you will be using.

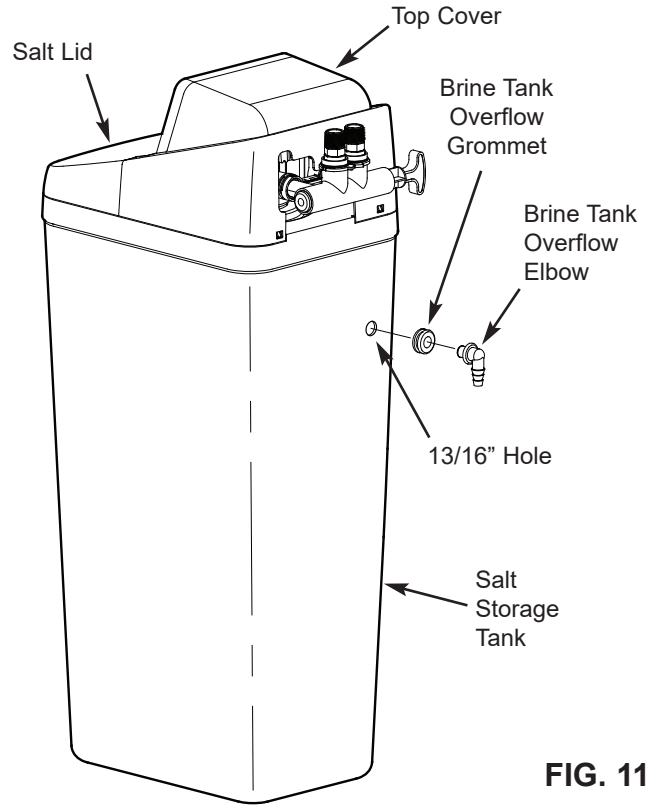

FIG. 11

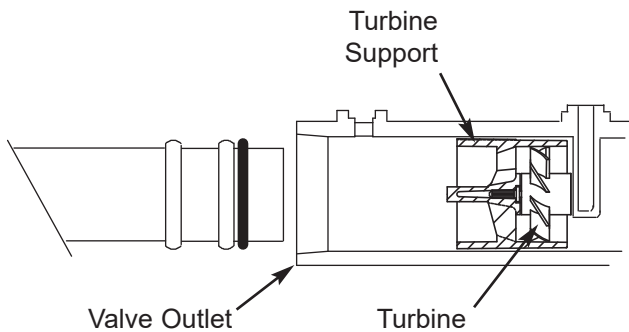

FIG. 10

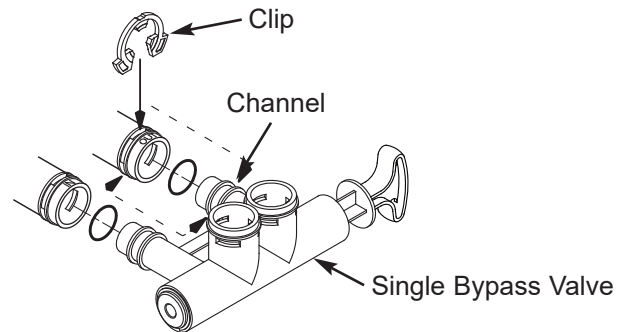

FIG. 12

Correct Assembly

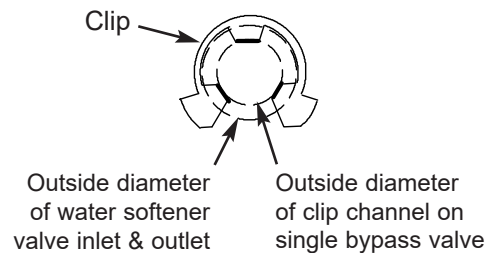

FIG. 13

NOTE: Be sure all 3 tabs of the clip go through the matching holes on the water softener valve inlet or outlet, and fully into the channel on the single bypass valve. Make sure that the tabs are fully seated.

Installation Instructions

COLD WATER PIPE GROUNDING

CAUTION: The house cold water pipe (metal only) is often used as a ground for the house electrical system. The 3-valve bypass type of installation, shown in Figure 8, will maintain ground continuity. If you use a plastic bypass valve at the unit, continuity is broken. To restore the ground, do the following:

1. Install a #4 copper wire across the removed section of main water pipe, securely clamping it at both ends (See Figure 14) - parts not included.

NOTE: Check local plumbing and electrical codes for proper installation of the ground wire. The installation must conform to them. In Massachusetts, plumbing codes of Massachusetts shall be conformed to. Consult with your licensed plumber.

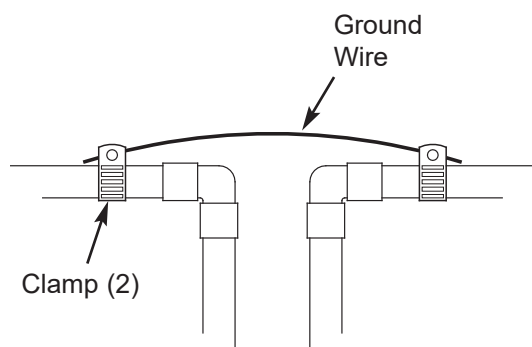

FIG. 14

INSTALL VALVE DRAIN HOSE

NOTE: See valve drain options on pages 6 & 7.

1. Measure, cut to needed length and connect the 3/8" drain line (provided) to the water softener valve drain fitting. Use a hose clamp to hold the hose in place.

IMPORTANT: If codes require a rigid drain line see "Valve Drain requirements" section.

2. Run the drain hose (or a rigid line) to the floor drain. Secure drain hose. This will prevent "whipping" during regenerations. **Be sure to provide a 1-1/2" minimum air gap to prevent possible sewer water backup.** See "Air Gap Requirements" section.

NOTE: In addition to a floor drain, you can use a laundry tub or standpipe as a drain point for this hose.. Avoid long drain hose runs, or elevating the hose more than 8 feet above the floor.

INSTALL SALT STORAGE TANK OVERFLOW HOSE

1. Measure, cut to needed length and connect the 3/8" drain line (provided) to the salt storage tank overflow elbow and secure in place with a hose clamp.
2. Route the hose to the floor drain, or other suitable drain point no higher than the drain fitting on the salt storage tank (This is a gravity drain). If the tank overfills with water, the excess water flows to the drain point. Cut the drain line to the desired length and route it neatly out of the way.

IMPORTANT: For proper operation of the water softener, do not connect the water softener valve drain tubing to the salt storage tank overflow hose.

ADD WATER AND SALT TO THE SALT STORAGE TANK

1. Using a container, add about three gallons of clean water into the salt storage tank.
2. Add salt to the storage tank. Use nugget, pellet or coarse solar salts with less than 1% impurities.

PLUG IN THE POWER SUPPLY

During installation, the water softener wiring may be moved or jostled from place. Be sure all leadwire connectors are secure on the back of the electronic board and be sure all wiring is away from the valve gear and motor area, which rotates during regenerations.

1. Plug the water softener's power supply into an electrical outlet that is not controlled by a switch and is approved by local codes.

NOTE: The water heater is filled with hard water and, as hot water is used, it will refill with conditioned water. In a few days, the hot water will be fully conditioned. To have fully conditioned hot water immediately, wait until the initial recharge is over. Then, drain the water heater (following instructions for water heater) until water runs cold.

PROGRAM THE CONTROLLER

1. Install the softener's top cover and salt lid.
2. Complete the Programming Steps on Pages 14 & 15.

Installation Instructions

RINSE OUT CARBON FINES

Small particles of carbon filtration material are generated during manufacturing and shipping, which will exit the media tank with the first water flow. These carbon “fines” are not harmful, but give the water a gray color and should be rinsed down the drain before any water from the conditioner is directed to the home’s faucets or water heater.

IMPORTANT: To avoid water or air pressure damage to conditioner inner parts, and to flush pipe chips or other residue from the water pipes, be sure to do the following steps exactly as instructed.

1. Make sure the water conditioner’s valve drain hose is hooked up and the open end directed to a floor drain, laundry tub or other suitable type of drain.
2. The system should be connected to electrical power.
3. Place bypass valve(s) in “bypass” position (see Figures 7 & 8). On a single valve, slide the stem inward to bypass. On a 3-valve bypass, close the inlet and outlet valves and open the bypass valve.
4. Fully open the house main water pipe shutoff valve.
5. Initiate a regeneration by pressing and holding for 3 seconds the RECHARGE button (see Figure 16 on page 14). The valve motor will start running and the valve will advance to the “Fill” position.
6. After you hear the valve motor stop running (valve in “Fill” position), press, but do not hold, the RECHARGE button. The valve will advance to the “Brine” position.
7. After you hear the valve motor stop running (valve in “Brine” position), press, but do not hold, the RECHARGE button. The valve will advance to the “Backwash” position.
8. Once the unit is in backwash, place bypass valve(s) in SERVICE, EXACTLY as follows:
 - a. Single Bypass Valve: Slowly, slide the valve stem outward toward service, pausing several times to allow the system to pressurize gradually.
 - b. 3-Valve Bypass: Fully close the bypass valve and open the outlet valve. Slowly open the inlet valve, pausing several times to allow the system to pressurize gradually.
9. Let the water conditioner complete the backwash and fast rinse cycles (takes about 20 minutes). When the regeneration ends, the conditioner’s valve returns to the service position.

SANITIZE THE WATER SOFTENER / SANITIZE AFTER SERVICE

Care is taken at the factory to keep your unit clean and sanitary. Materials used to make the unit will not infect or contaminate your water supply, and will not cause bacteria to form or grow. However, during shipping, storage, installation and operation, bacteria could get into the unit. For this reason, sanitizing as follows is suggested* when installing.

1. Open the salt lid and pour about 3 oz. (6 table-spoons) of household bleach into the softener brinewell.
2. Make sure the bypass valve(s) is in the “service” (open) position.
- 3 **Start a recharge:** Press the RECHARGE button and hold for 3 seconds, until “Recharge Now” begins to flash in the display. This recharge draws the sanitizing bleach into and through the water softener. Any air remaining in the unit is purged to the drain.
4. After the recharge has completed, fully open a cold water faucet, downstream from the softener, and allow 50 gallons of water to pass through the system. This should take at least 20 minutes. Close the faucet.

*Recommended by the Water Quality Association. On some water supplies, the unit may need periodic disinfecting.

Installation Instructions

TEST FOR LEAKS

To check for leaks, complete the following steps:

1. Fully open two nearby cold water faucets downstream from the water softener.
2. Observe steady flow from both faucets.
3. After about three minutes, open a hot water faucet for about one minute, or until all air is expelled, and then close this faucet.
4. Close both cold water faucets.
5. Check your plumbing work for leaks, and fix right away if any are found. Be sure to observe previous caution notes.

NOTE: If this procedure is performed on a new softener, water coming from the taps may initially be discolored. This normally occurs the first time water runs through the resin bed. The discoloration will not last more than a few minutes.

RESTART THE WATER HEATER

1. Turn on the electricity or fuel supply to the water heater and relight the pilot, if applicable.

NOTE: The water heater is filled with hard water and, as hot water is used, it refills with conditioned water. In a few days, the hot water will be fully conditioned. To have fully conditioned hot water immediately, wait until the initial recharge (previous step) is over. Then, drain the water heater (following instructions for water heater) until water runs cold.

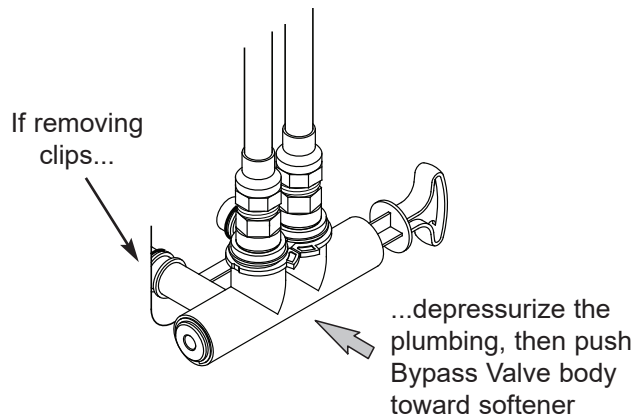

FIG. 15

Programming the Water Softener

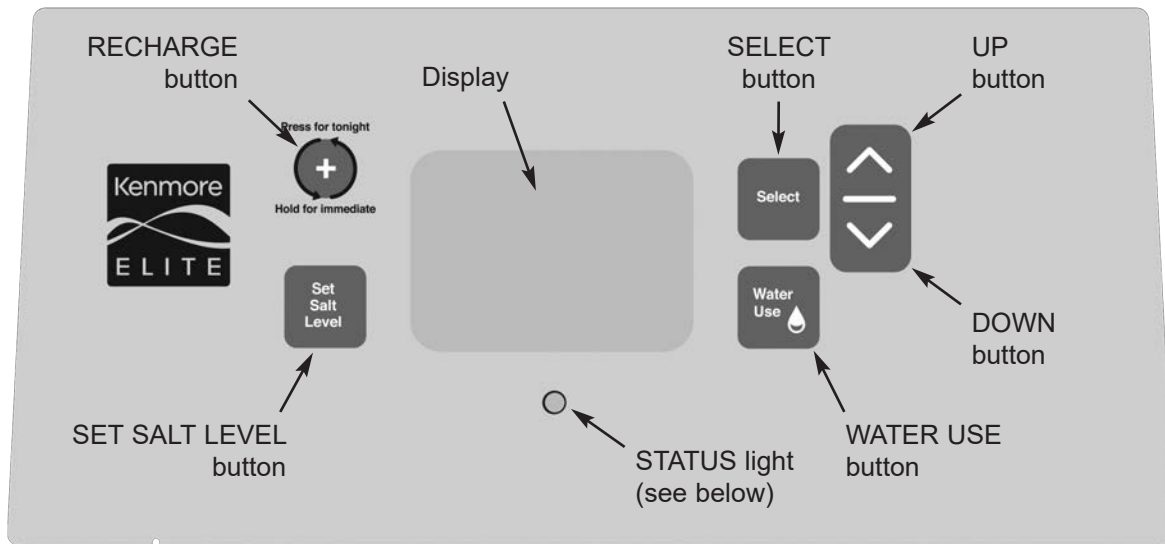

FIG. 16

STATUS LIGHT

When the Kenmore Elite® hybrid water softener is connected to electrical power, the status light on the control panel will be on or flashing, as follows:

- **Status light flashing rapidly, with “PRESENT TIME” shown in the display and the clock flashing slowly** - The present time needs to be set, either during initial start up or after a long power outage. See “Set Present Time of Day”, at right.
- **Status light flashing slowly, along with the salt level indicators in the display** - The salt monitor system indicates a low salt level and needs to be set. See “Salt Monitor System” on Page 15.
- **Status light flashing rapidly, with “Err” shown in the display** - The electronic self-diagnostics have detected a problem. See “Troubleshooting” on Page 21.
- **Status light on steady (not flashing)** - The system has power applied and does not require any attention.

PROGRAM THE SOFTENER

When the power supply is plugged into the electrical outlet, the model code (520P) and a software version number (example: J3.9), are briefly shown in the display. Then the words “PRESENT TIME” appear and 12:00 PM begins to flash.

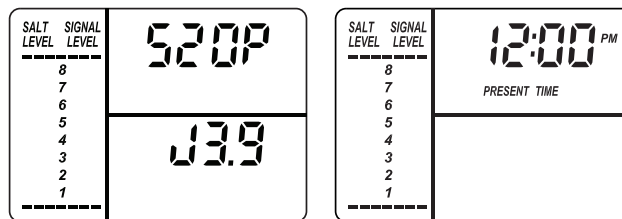

FIG. 17

SET PRESENT TIME OF DAY

If the words “PRESENT TIME” do not show in the display, press the SELECT button a few times until they do.

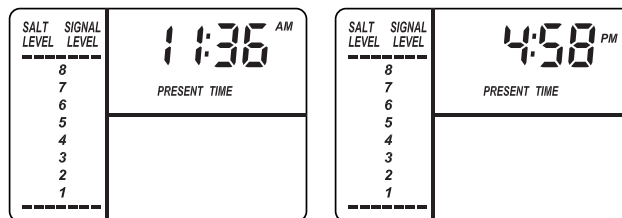

FIG. 18

1. Press the Δ UP or ∇ DOWN buttons to set the present time. Up moves the display ahead; down sets the time back. Be sure AM or PM is correct.

continued on next page

Programming the Water Softener

continued from previous page

NOTE: Press buttons and quickly release to slowly advance the display. Hold the buttons down for fast advance.

- When the correct time is displayed, press the SELECT button, and the display will change to show the "Hardness" screen.

SET WATER HARDNESS NUMBER

If you completed the previous step, the word "HARDNESS" should show in the display. Otherwise, press the SELECT button several times until it does.

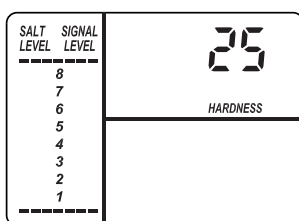

FIG. 19

- Press the Δ UP or ∇ DOWN buttons to set the hardness of your water supply, in grains per gallon. The default is 25.

NOTE: If your water supply contains iron, compensate for it by adding to the water hardness number. For example, assume your water is 20 gpg hard and contains 2 ppm iron. Add 5 to the hardness number for each 1 ppm of iron. In this example, you would use 30 for your hardness number.

$$\begin{array}{r}
 20 \text{ gpg hardness} \\
 2 \text{ ppm iron} \times 5 = 10 \quad +10 \\
 \text{(times)} \qquad \qquad \qquad 30 \text{ HARDNESS NUMBER}
 \end{array}$$

- When finished setting your water's hardness number, press the SELECT button, and the display will change to show the "Recharge Time" screen.

SET RECHARGE (REGENERATION) START TIME

If you completed the previous step, the words "RECHARGE TIME" should show in the display. Otherwise, press the SELECT button several times until they do.

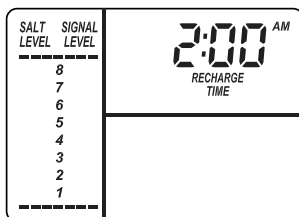

FIG. 20

- The softener's default recharge start time is 2:00 AM. This is normally a time of day when water is not being used in the household. Hard water bypasses the softener if the household draws water during the recharge cycle. If a different recharge start time is desired, press the Δ UP or ∇ DOWN buttons to change the time, in 1-hour increments. Be sure AM or PM is correct.
- When the desired recharge start time is displayed, press the SELECT button, and the display will change to show one of the "Salt Type" screens shown below.

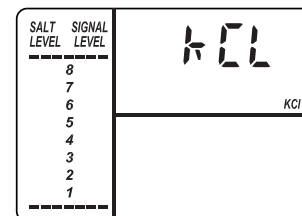
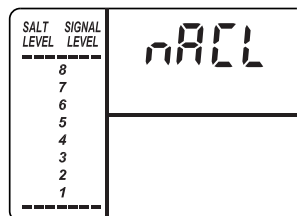

FIG. 21

SET SALT TYPE

If you completed the previous step, either "NaCl" (for Sodium Chloride) or "KCl" (for Potassium Chloride) should show in the display. Otherwise, press the SELECT button several times until one of them does.

- Press the Δ UP or ∇ DOWN buttons to set the type of salt you will be using in your water softener. The default is NaCl (standard Sodium Chloride water softener salt). If you will be using KCl (Potassium Chloride) instead, be sure to set salt type to KCl. This setting adjusts the regeneration cycle times to compensate for the different rate at which KCl dissolves. See also Page 18 for more information on salt types.
- When the correct salt type is displayed, press the SELECT button, and the display will return to the normal run (time of day) screen.

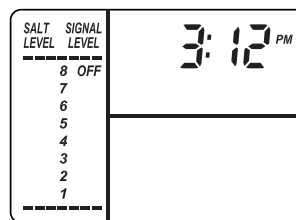

FIG. 22

Controller Features

EXTRA RECHARGE

Sometimes, a manually initiated recharge (regeneration) may be desired, or needed. Two examples are:

- You have used more water than usual (guests visiting) and you may run out of soft water before the next automatic regeneration.
- You did not add salt to the softener before it ran out. Add salt to the softener before regenerating.

You can start a regeneration immediately, or you can set the controller to regenerate at the next preset recharge time (2:00 AM, or as set).

RECHARGE NOW

Press the RECHARGE button and hold for 3 seconds, until the words “RECHARGE”, “Serv” and “Fill” begin to flash in the display. The softener enters the fill cycle of regeneration immediately. This regeneration will take about 2 hours to complete. Then, you will have soft water again.

NOTE: If the “Clean Feature” is set ON, the normal regeneration cycle is preceded by a cleaning backwash and rinse. The words “CLEAN” and “Bkwhs” or “Rinse” flash in the display, along with the minutes of the clean cycle remaining.

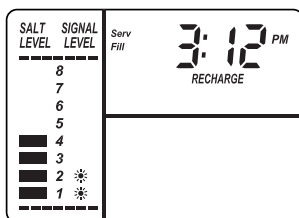

FIG. 23

RECHARGE TONIGHT

Press and release (do not hold) the RECHARGE button. “RECHARGE TONIGHT” will begin flashing in the display, and the softener will begin regeneration at the next preset recharge time (2:00 AM, or as set). If you decide to cancel the regeneration before it starts, press and release the RECHARGE button once more. “RECHARGE TONIGHT” will stop flashing in the display.

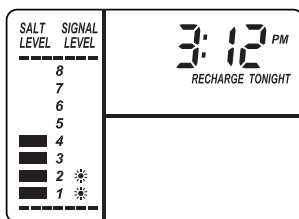

FIG. 24

SALT MONITOR SYSTEM

The water softener has a salt monitor indicator light to remind you to add salt to the storage tank.

NOTE: You must set salt level each time salt is added to the water softener.

NOTE: The salt monitor system estimates salt levels, and accuracy will vary with different salts.

To set this monitor system:

1. Lift the salt lid and level the salt in the storage tank.
2. The salt level scale, on the brinewell inside the tank, has numbers from 0 to 8 (see Fig. 25). Observe the highest number the leveled salt is at, or closest to.

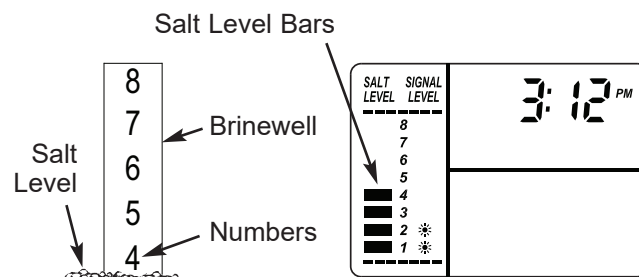

FIG. 25

3. Press the SET SALT LEVEL button as many times as necessary to make the salt level bars in the display (see Fig. 25) match the number on the brinewell. At level 2 or below, the Low Salt light will flash (See Page 12).
4. If you want to turn the salt monitor off, press the SET SALT LEVEL button past 8, until “OFF” shows in the display next to the number 8.

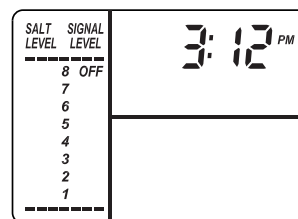

FIG. 26

Controller Features

OPTIONAL SETTINGS:

- SALT EFFICIENCY
- CLEAN FEATURE
- CLEAN FEATURE MINUTES
- 97% FEATURE
- 12 / 24 HOUR CLOCK
- GALLONS / LITERS
- MAXIMUM DAYS BETWEEN REGENERATIONS
- BACKWASH & FAST RINSE TIMES

1. To set any of these options, press and hold SELECT for 3 seconds until "000" shows in the display. Then press (do not hold) SELECT again to display one of the "Salt Efficiency" screens shown below.

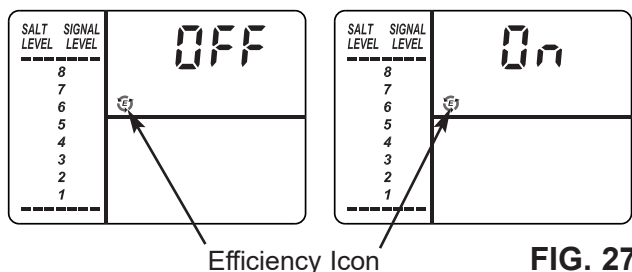

FIG. 27

SALT EFFICIENCY: When this feature is ON, the water softener will operate at salt efficiencies of 4000 grains of hardness per pound of salt or higher. The softener may recharge more often using smaller salt dosage and less water. This softener is shipped with the efficiency feature set OFF. Use the Δ UP or ∇ DOWN buttons to change between OFF and ON. An efficiency icon will be displayed when this feature is ON.

California Efficiency Requirement

Your Kenmore® water softener has a "High Efficiency" feature that can be set ON or OFF. This softener is shipped with the efficiency feature set OFF, which will utilize the maximum rated capacity while most often achieving maximum salt efficiencies. When installing this unit in the State of California, you **MUST** turn the efficiency feature ON. The softener may initiate more frequent recharges, but it will operate at 4000 grains per pound of salt or higher.

2. Press SELECT again to display one of the "Clean" screens shown below.

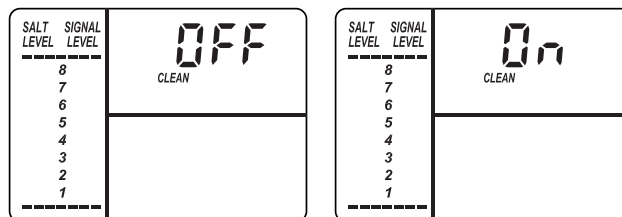

FIG. 28

CLEAN: This feature is beneficial on water supplies containing iron and/or high amounts of sediments (sand, silt, dirt, etc.). When set to ON, a backwash and fast rinse cycle will occur first, preceding the normal regeneration sequence. This provides extra cleaning of the resin bed before it is regenerated with the salt brine. To conserve water, if your water supply does not contain iron or sediments, be sure this feature is set to OFF. The default is OFF. Use the Δ UP or ∇ DOWN buttons to change between OFF and ON.

3. Press SELECT again to display the "Clean Time" screen shown below.

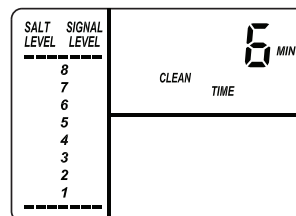

FIG. 29

CLEAN FEATURE MINUTES: If you have set the Clean Feature ON, the length of the extra backwash cycle automatically is set to 6 minutes. However, you can adjust this time from 1 to 15 minutes in length. To change this cycle time, use the Δ UP button to increase the time, or the ∇ DOWN button to shorten the time. If no change is desired, continue to next step.

4. Press SELECT again to display the "97%" screen.

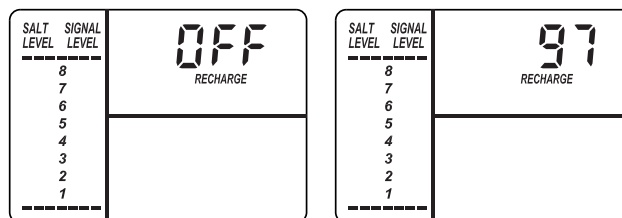

FIG. 30

Controller Features

97% FEATURE: The 97% Feature can save salt and water by regenerating when 97% of the softener's capacity has been used up. With this feature ON, the regeneration can occur at any time (whenever the system has reached 97% of its capacity). The default is OFF. If this feature is desired, turn it on by pressing the \triangle UP button.

- Press SELECT again to display the "12 or 24 hr" screen.

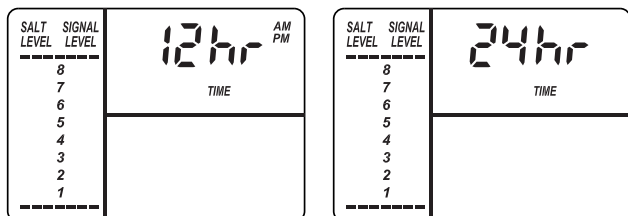

FIG. 31

12 OR 24 HOUR CLOCK: All time displays are shown in 12 hour (AM/PM) time format at the default setting. If 24 hour time format is desired, set to 24 hr by pressing the \triangle UP button.

- Press SELECT again to display the "Gallons or Liters" screen.

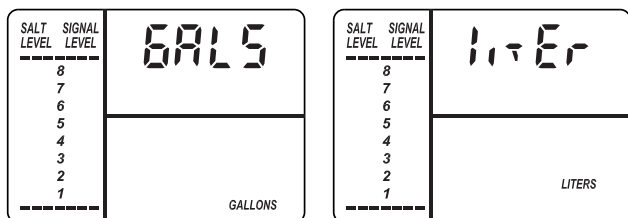

FIG. 32

GALLON OR LITER READINGS: Water usage and flow rate displays are shown in gallons at the default setting. If you prefer liters, change this setting from "Gals" to "Liter" by pressing the \triangle UP button.

- Press SELECT again to display the "Recharge Days" screen.

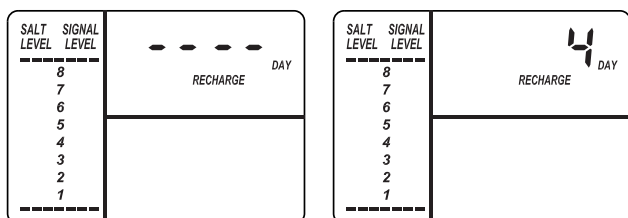

FIG. 33

MAXIMUM DAYS BETWEEN REGENERATIONS: The electronic controller automatically determines regeneration frequency. This provides the greatest operating efficiency and, under most conditions this feature will be left in its default mode. However, you can set this feature to force a regeneration every set number of days. You may want to do this if, for example, your water supply contains iron and you want the softener to regenerate at least once every few days to keep the resin bed clean. Use the \triangle UP or ∇ DOWN buttons to change the number of days (up to 15). If no change is desired, continue to next step.

- Press SELECT again to display the "Backwash Time" setting screen.

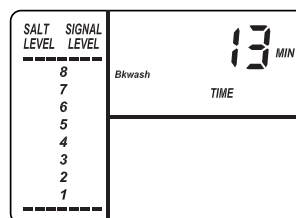

FIG. 34

BACKWASH & FAST RINSE TIMES: If you experience salty tasting water after regeneration, you may need to increase the backwash and fast rinse times. The default backwash time is 13 minutes and the default fast rinse time is 6 minutes. However, you may increase or decrease the backwash and fast rinse times, in 1 minute increments. If you wish to change the backwash time, use the \triangle UP or ∇ DOWN buttons to set the backwash time between 1 and 30 minutes*. Then press SELECT to display the "Fast Rinse Time" setting screen.

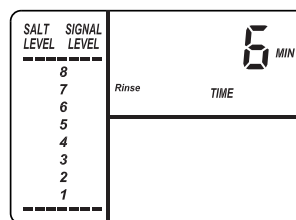

FIG. 35

If you wish to change the fast rinse time, use the \triangle UP or ∇ DOWN buttons to set the fast rinse time between 1 and 30 minutes.*

* Setting backwash and/or fast rinse times too low may result in salty tasting water after regeneration.

- Press SELECT to return to the normal run (time of day) screen.

Controller Features

WATER FLOW THROUGH THE SOFTENER

To view the flow rate through the softener in liters (or gallons) per minute, press the WATER USE button. If soft water is in use, the flow rate will be displayed to the nearest tenth of a liter (or gallon). The display will show "0" when all faucets and water using appliances are off.

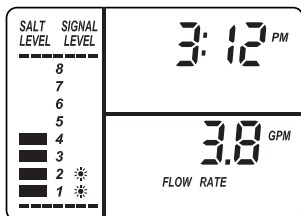
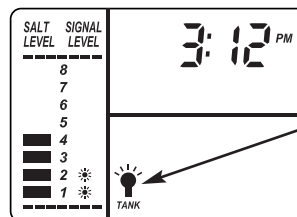

FIG. 36

TANK LIGHT

A light inside the salt storage tank will come on whenever you open the salt lid. A "Tank Light" icon is displayed when this light is on. The light turns off when you close the salt lid. It will also turn off automatically after 15 minutes if the salt lid is left open.



Tank Light Icon

FIG. 39

AVERAGE DAILY GALLONS OR LITERS

Press the WATER USE button a second time to display the average number of gallons (or liters) of soft water that the household uses each day. This water usage figure is recalculated daily by the electronic controller. To turn this display off, press the WATER USE button once again.

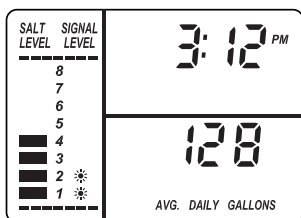

FIG. 37

POWER OUTAGE MEMORY

If electrical power to the softener is interrupted, the time display is blank, but the electronic controller keeps correct time for several hours. When power is restored, you must reset the present time only if the display is flashing. All other settings are maintained and never require resetting unless a change is desired. If the time is flashing after a long power outage, the softener continues to work as it should to provide you with soft water. However, regenerations may occur at the wrong time of day until you reset the clock to the correct time of day.

NOTE: If the water softener was regenerating when power was lost, it will now finish the cycle.

RECHARGE TIME REMAINING & VALVE POSITION INDICATORS

One of the valve position indicators (Serv, Fill, Brine, Bkwsh, Rinse) is displayed while the softener is recharging. RECHARGE flashes in the display and, beginning with Brine, the minutes of recharge remaining before return to service appears in place of the present time. When the valve is moving from one cycle to another, both position indicators are flashing.

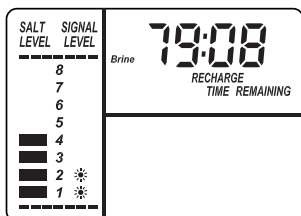

FIG. 38

Questions? Visit www.kenmorewatersolutions.com or call 1-800-695-2761.

Routine Maintenance

ADDING SALT

Open the salt lid and check the salt storage level frequently. If the water softener uses all the salt before you refill it, you will experience hard water. Until you have established a refilling routine, check the salt every two or three weeks. Always add if less than 1/4 full.

NOTE: In humid areas, it is best to keep the salt storage level lower, and to refill more often to avoid salt "bridging".

Recommended Salt: Nugget, pellet or coarse solar salts with less than 1% impurities.

Salt Not Recommended: Rock salt, high in impurities, block, granulated, table, ice melting, ice cream making salts, etc.

BREAKING A SALT BRIDGE

Sometimes, a hard crust or salt "bridge" forms in the brine tank. It is usually caused by high humidity or the wrong kind of salt. When the salt "bridges," an empty space forms between the water and the salt. Then, salt will not dissolve in the water to make brine. Without brine, the resin bed is not recharged and hard water will result.

If the storage tank is full of salt, it is difficult to tell if you have a salt bridge. A bridge may be underneath loose salt. Take a broom handle, or like tool, and hold it next to the water softener. Measure the distance from the floor to the rim of the water softener. Then, gently push the broom handle straight down into the salt. If a hard object is felt before the pencil mark is even with the top, it is most likely a salt bridge. Gently push into the bridge in several places to break it. Do not use any sharp or pointed objects as you may puncture the brine tank. Do not try to break the salt bridge by pounding on the outside of the salt tank. You may damage the tank.

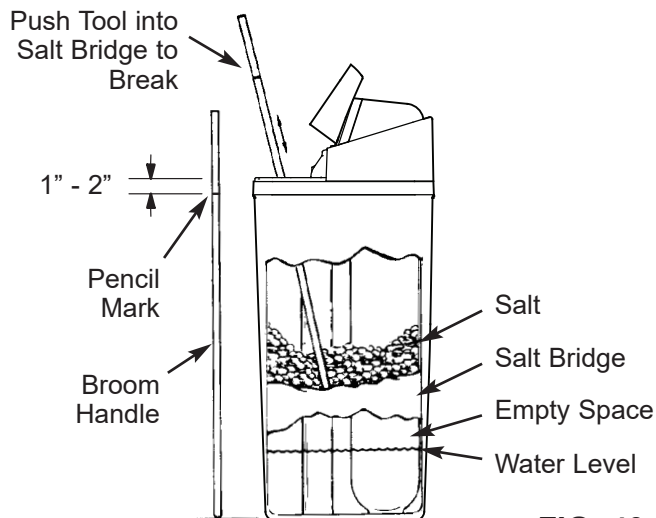
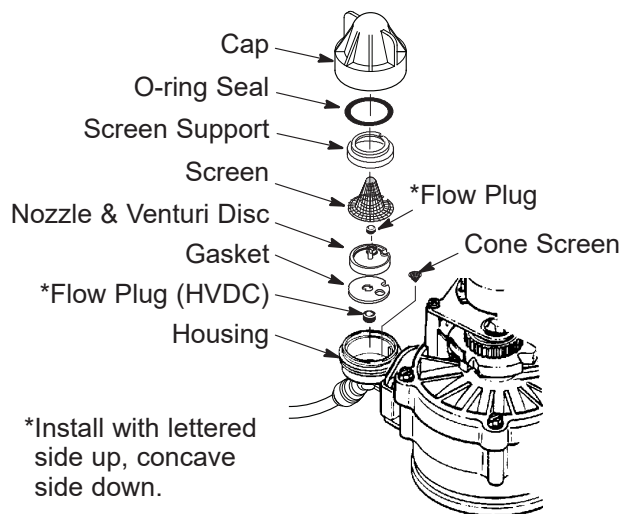

FIG. 40

CLEANING THE NOZZLE & VENTURI

A clean nozzle & venturi (See Figure 41) is a necessity for the water softener to work properly. This small component creates the suction to move brine from the brine tank, into the resin tank. If it should become plugged with sand, silt, dirt, etc., the water softener will not work, and hard water will result.



IMPORTANT: Be sure small hole in the gasket is centered directly over the small hole in the nozzle & venturi housing. Be sure the numbers are facing up

FIG. 41

To get access to the nozzle & venturi, remove the water softener's top cover. Put the bypass valve(s) into the bypass position. Be sure the water softener is in soft water (service) cycle (no water pressure at nozzle & venturi). Then, holding the nozzle & venturi housing with one hand, unscrew the cap. Do not lose the o-ring seal. Lift out the screen support and screen. Then, remove the nozzle & venturi disc, gasket and flow plug(s). Wash the parts in warm, soapy water and rinse in fresh water. Be sure to clean both the top and bottom of the nozzle & venturi disc. If needed, use a small brush to remove iron or dirt. Do not scratch, misshape, etc., surfaces of the nozzle & venturi.

Gently replace all parts in the correct order. Lubricate the o-ring seal with silicone grease and locate in place. Install and tighten the cap by hand, while supporting the housing. Overtightening may break the cap or housing. Put the bypass valve(s) into service (soft water) position.

Recharge the softener to reduce water level in the tank. This will also assure that the softener is completely recharged and ready to provide softened water again. Check the water level in the tank by looking down the brinewell. If the water level does not drop after a recharge, the problem has not been resolved. Call 1-800-695-2761.

Routine Maintenance

PROTECT THE WATER SOFTENER FROM FREEZING

If the softener is installed where it could freeze (summer cabin, lake home, etc.), you must drain all water from it to stop possible freeze damage. To drain the softener:

1. Close the shut-off valve on the house main water pipe, near the water meter or pressure tank.
2. Open a faucet in the soft water pipes to vent pressure in the softener.
3. Move the stem in the single bypass valve to bypass. Close the inlet and outlet valve in a 3 valve bypass system, and open the bypass valve. If you want water in the house pipes again, reopen the shut-off valve on the main water pipe.
4. Unplug the power supply at the wall outlet. Open the salt lid and remove the softener's top cover. Take off both drain hoses if they will interfere with moving the softener into position over the drain.
5. Carefully remove the large holding clips at the softener inlet and outlet. Separate the softener from the plastic installation adaptors, or from the bypass valve.
6. Lay a piece of 2 inch thick board near the floor drain (See Figure 42).

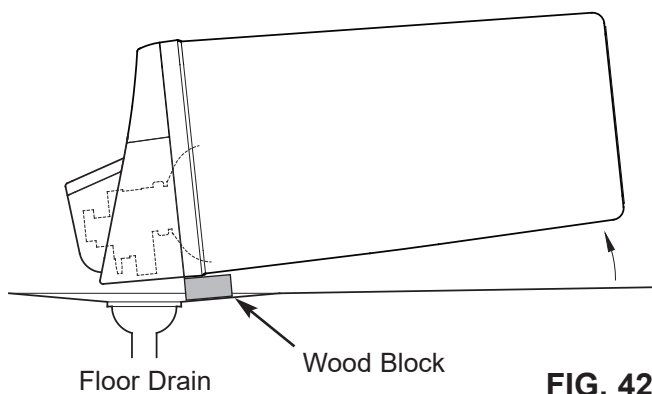

7. Move the softener close to the drain. Slowly and gently, tip it over until the rim rests on the wood block with the inlet and outlet over the drain. Do not allow the softener's weight to rest on the inlet and outlet fittings or they may break.
8. Tip the bottom of the softener up a few inches and hold until all water has drained. Leave the softener laying like this until you are ready to use it. Plug the inlet and outlet with clean rags to keep dirt, bugs, etc. out.

CLEANSING FEATURE

The cleansing feature keeps larger particles of sediment from entering the home's plumbing system. As water passes through the softener, the larger sediment particles are collected in the integrated basket and then rinsed to the drain before each regeneration. The cleansing feature provides added protection for water using appliances by reducing the chance of larger particles entering the various products valves and screens. The "Clean Feature" may be turned ON to provide an extra backwash that will help keep the cleansing screen clean. The default is OFF.

IMPORTANT: The cleansing feature is not intended to replace pretreatment filtration. For problem water applications, additional sediment filtration is recommended.

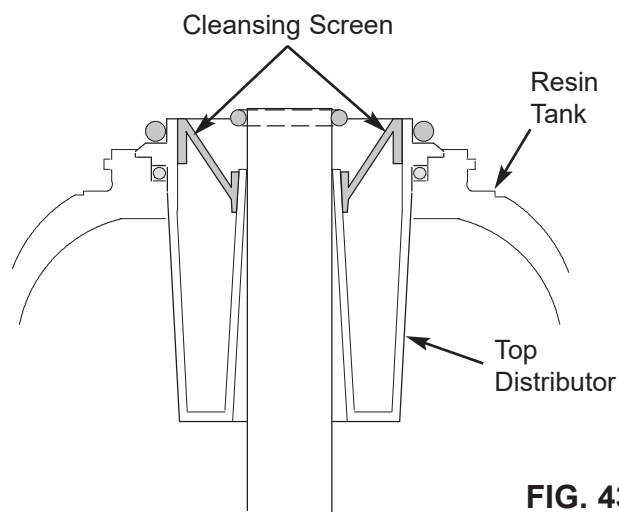

Questions? Visit www.kenmorewatersolutions.com or call 1-800-695-2761.

Troubleshooting Guide

PROBLEM	CAUSE	CORRECTION
No soft water	1. No salt in the storage tank.	Refill with salt and then use RECHARGE NOW feature.
No soft water & display is blank	1. Power supply unplugged at wall outlet, or power cable disconnected from back of electronic board or power supply malfunction.	Check for loss of power and correct. Reset electronic controls and then use RECHARGE NOW feature.
	2. Fuse blown, circuit breaker popped, or circuit switched off (See "Power Outage Memory" on Page 17).	Replace fuse, reset circuit breaker, or switch circuit on, and then use RECHARGE NOW feature.
	3. Electronic control board malfunction.	Replace electronic control board (See Page 25).
No soft water & salt level not dropping	1. Salt storage tank "bridged".	Refer to "Breaking a Salt Bridge" section to break.
	2. Bypass valve(s) in "bypass" position.	Move bypass valve(s) to "service" position.
No soft water & salt storage tank full of water, water running to drain while unit is in the soft water cycle	1. Dirty, plugged or damaged nozzle & venturi assembly	Take apart, clean and inspect nozzle & venturi (See "Cleaning the Nozzle & Venturi" section).
	2. Inner valve fault causing leak.	Replace seals and rotor.
	3. Valve drain hose is plugged.	Hose must not have any kinks, sharp bends or any water flow blockage (See "Valve Drain Requirements" section).
	4. Valve drain line and Salt Storage Tank overflow drain connected together by a tee.	Disconnect tee and run separate drain lines.
	5. Low or high system water pressure (low pressure may disrupt brine draw during recharge, high pressure may cause inner valve parts failure).	If pressure is low, increase well pump output to a minimum 20 psi. If daytime pressure is over 100 psi, add a pressure reducing valve in the supply pipe to the softener. Contact a licensed plumber.
	6. Brine float dirty or broken.	Clean or replace Brine Valve Float Assembly.
	7. Leak between valve and resin tank.	Replace o-rings between resin tank and valve.
Water hard sometimes	1. Incorrect time set.	Check and change time setting.
	2. Incorrect water hardness set.	Refer to "Set Water Hardness" section to set correctly.
	3. Incorrect model code programmed.	Refer to "Program the Water Softener" section to set correctly.
	4. Hot water being used when softener is regenerating.	Avoid using hot water while the softener is regenerating, as the water heater will fill with hard water.
	5. Possible increase in water hardness.	Test untreated water for hardness and iron, and program the water softener accordingly (See "Set Water Hardness") section to set.
	6. Leaking faucet or toilet valve. Excessive water usage.	A small leak can waste hundreds of gallons of water in a few days. Fix all leaks and always fully close faucets.
Iron in water	1. Clear water iron in water supply.	Test untreated water for hardness and iron, and program the water softener accordingly (See "Set Water Hardness") section to set.
	2. Iron in soft water.	Clean resin bed with Resin Bed Cleaner. Follow instructions on package.
	3. Bacterial or organic bound iron.	Cannot be treated by water softener.
Resin in household plumbing	1. Crack in distributor or riser tube.	Replace resin tank assembly.
Salt storage tank leaking	1. Crack in brine tank.	Replace salt storage tank assembly.
Motor stalled or clicking	1. Motor malfunction or internal valve fault causing high torque on motor.	a. Replace rotor/seal. b. Replace motor & switch.
Error code Err1, Err3 or Err4 appears	1. Fault in wiring harness or connections to position switch.	Replace wiring harness or connections to position switch.
	2. Fault in switch.	Replace switch.
	3. Fault in valve causing high torque.	Replace rotor/seal.
	4. Motor inoperative.	Replace motor.
Error code Err5	1. Electronic control malfunction.	Replace electronic control board.

Troubleshooting

AUTOMATIC ELECTRONIC DIAGNOSTICS

This water softener has a self-diagnostic function for the electrical system (except input power and/or water meter). The water softener monitors electronic components and circuits for correct operation. If a malfunction occurs, an error code appears in the display.

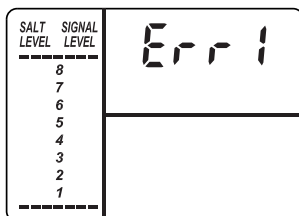

FIG. 43

While an error code appears in the display, all buttons are inoperable except the SELECT button. SELECT remains operational so the service person can perform the Manual Advance Diagnostics, see below, to further isolate the problem.

TO REMOVE AN ERROR CODE:

1. Unplug power supply from electrical outlet.
2. Correct problem.
3. Plug power supply back in.
4. Wait 8 minutes. The error code will return if the problem was not corrected.

MANUALLY INITIATED ELECTRONIC DIAGNOSTICS

1. To enter diagnostics, press the SELECT button and hold for three seconds. The display will change to show turbine count, valve cycle position, and position switch status (open or closed).

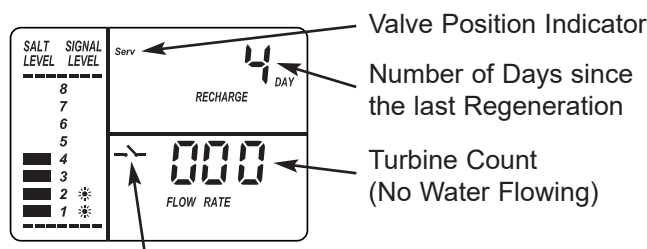

Position Switch Indicator (Open)

FIG. 44

TURBINE OPERATION: If no water is flowing through the softener, the turbine indicator displays three zeros. When water is flowing, a 000 to 140 count repeats for each gallon (3.8 liters) of water passing through the turbine. To check for positive operation of the turbine if zeros are shown, open a nearby soft water faucet and observe the turbine count. If you don't get a reading in the display with faucet open, pull the sensor housing from the valve outlet port (see Fig. 45). Pass

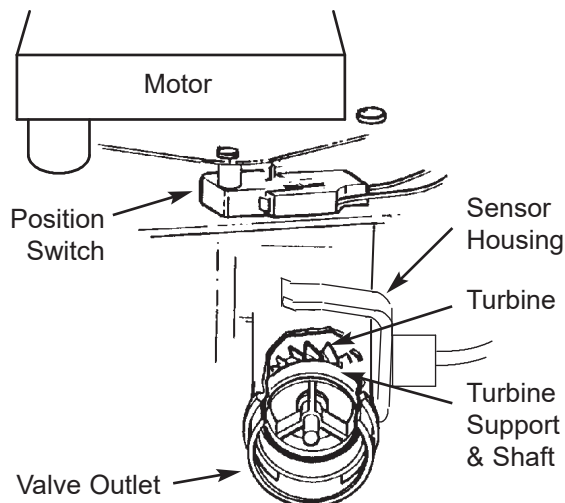

FIG. 45

a small magnet back and forth in front of the sensor. You should get a reading in the display. If you get a reading, unhook the inlet and outlet plumbing and check the turbine for binding.

POSITION SWITCH STATUS: With the valve in service, or any of the recharge cycle positions, the position switch indicator will show the switch open. While the valve is rotating from one position to another, the position switch indicator will show the switch closed. There is likely a problem if indications vary from this pattern.

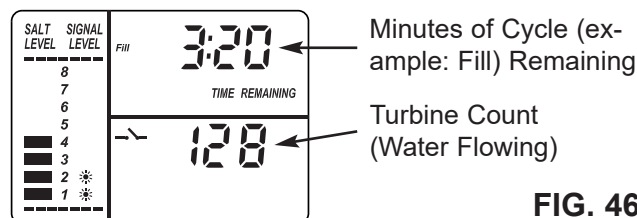

FIG. 46

OTHER INFORMATION: While in the diagnostics screen, the following information is available and may be beneficial for various reasons. This information is retained by the electronic controller from the first time electrical power is applied to the unit.

- Press and hold the Δ UP button to display the number of days this controller has had electrical power applied.
- Press and hold the ∇ DOWN button to display the number of regenerations initiated by this controller since the model code number was entered.

NOTE: If the electronic controller is left in the diagnostic display (or a flashing display when setting times or hardness), the normal time of day display automatically returns if a button has not been pressed for 4 minutes. To return to the diagnostic display, repeat step 1, above.

Troubleshooting

RESETTING TO FACTORY DEFAULTS

To reset the electronic controller to its factory default for all settings (time, hardness, etc.):

1. Press the SELECT button and hold it until the display changes twice to show the flashing model code.
2. Press the \triangle UP button to display a flashing "SoS".

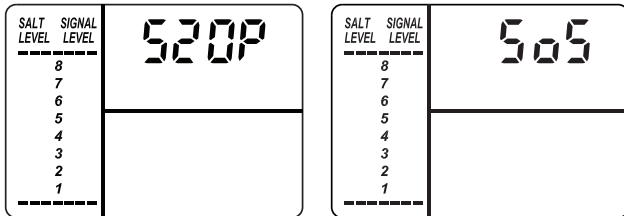

FIG. 47

3. Press the SELECT button, and the electronic controller will restart.
4. Set the present time, hardness, etc., as described on pages 12 & 13.

MANUAL ADVANCE REGENERATION CHECK

This check verifies proper operation of the valve motor, brine tank fill, brine draw, regeneration flow rates, and other controller functions. Always make the initial checks first, and perform the manually initiated electronic diagnostics.

NOTE: The display must show a steady time (not flashing). If an error code shows, first press the SELECT button to enter the diagnostic display.

1. Press the RECHARGE button and hold for 3 seconds. RECHARGE begins to flash as the softener's valve advances from the service to fill position.
2. Shine a flashlight down the brinewell and observe fill water entering the tank.
3. If water does not enter the tank, look for an obstructed nozzle, venturi, fill flow plug, brine tubing, or brine valve riser pipe.
4. After observing fill, press the RECHARGE button to move the softener into brining. A slow flow of water to the drain will begin. Verify brine draw from

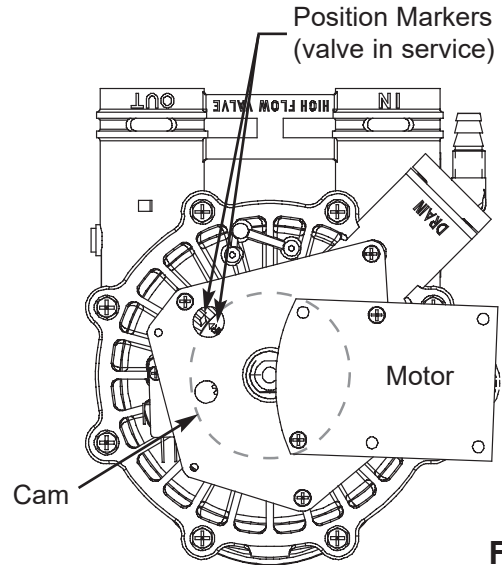

FIG. 48

the brine tank by shining a flashlight into the brinewell and observing a noticeable drop in the liquid level.

5. If the softener does not draw brine:
 - nozzle and/or venturi dirty
 - nozzle and venturi not seated properly on gasket
 - restricted drain (check drain fitting and hose)
 - ineffective nozzle and venturi seal
 - other inner valve problem (rotor seal, rotor & disc, wave washer, etc.)

NOTE: If water system pressure is low, an elevated drain hose may cause back pressure, stopping brine draw.

6. Again press RECHARGE to move the softener into backwash. Look for a fast flow of water from the drain hose.
7. An obstructed flow indicates a plugged top distributor, backwash flow plug or drain hose.
8. Press RECHARGE to move the softener into fast rinse. Again look for a fast drain flow. Allow the softener to rinse for a few minutes to flush out any brine that may remain in the resin tank from the brining cycle test.
9. To return the softener to service, press RECHARGE once more.

Wiring Schematic

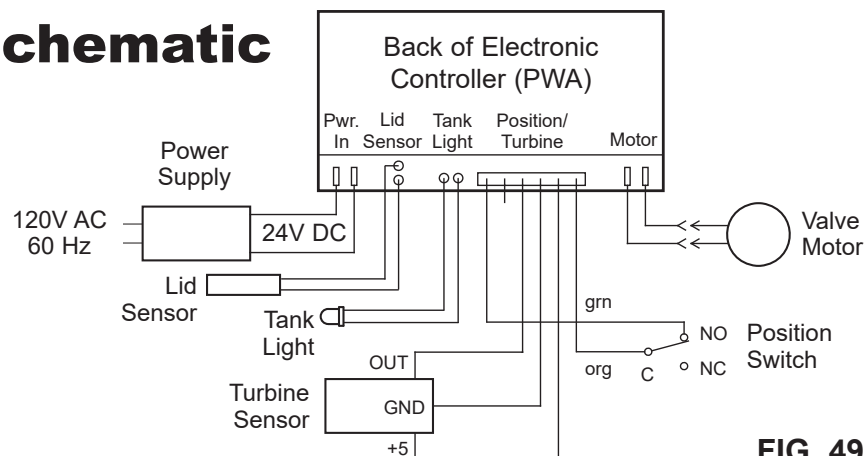
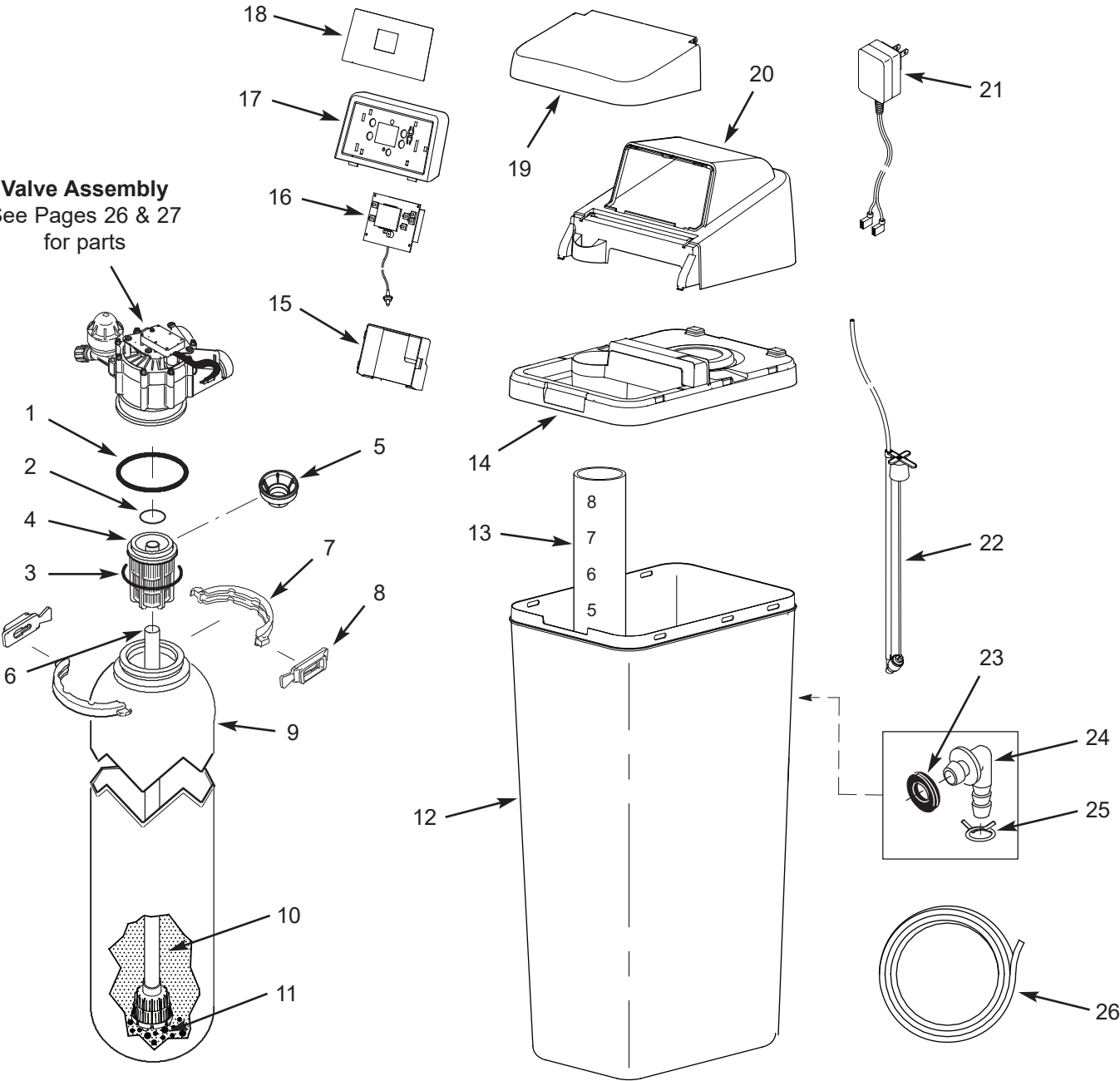

FIG. 49

Softener Exploded View

Valve Assembly
See Pages 26 & 27
for parts



Softener Parts List

Key No.	Part No.	Description
–	7112963	Distributor O-Ring Kit (includes Key Nos. 1-3)
1	↑	O-Ring, 2-7/8" x 3-1/4"
2	↑	O-Ring, 13/16" x 1-1/16"
3	↑	O-Ring, 2-3/4" x 3"
4	7077870	Top Distributor
5	7265025	Filter Screen
6	7327584	Repl. Bottom Distributor
–	7331177	Tank Neck Clamp Kit (includes 2 ea. of Key Nos. 7 & 8)
7	↑	Clamp Section (2 req.)
8	↑	Retainer Clip (2 req.)
9	7247996	Repl. Resin Tank, 10" x 40"
10	0502272	Resin, 1 cu. ft.
	7336834	Activated Carbon, 1 cu. ft.
11	7124415	Gravel
12	7391339	Brine Tank
13	7137824	Brinewell

Key No.	Part No.	Description
14	7391371	Rim
15	7391729	Electronics Enclosure, Rear
16	7327835	Repl. Electronic Control Board (PWA)
17	7392987	Faceplate (order decal below)
18	7394688	Faceplate Decal
19	7393488	Salt Lid, with magnet (order decal below)
■	7393365	Instruction Decal
20	7391478	Top Cover
21	7351054	Power Supply, 24V DC
22	7381180	Brine Valve Assembly
–	7331258	Overflow Hose Adaptor Kit (includes Key Nos. 23-25)
23	↑	Grommet
24	↑	Adaptor Elbow
25	↑	Hose Clamp
26	7139999	Drain Hose

■ Not illustrated.

Questions? Visit www.kenmorewatersolutions.com or call 1-800-695-2761.

Valve Exploded View

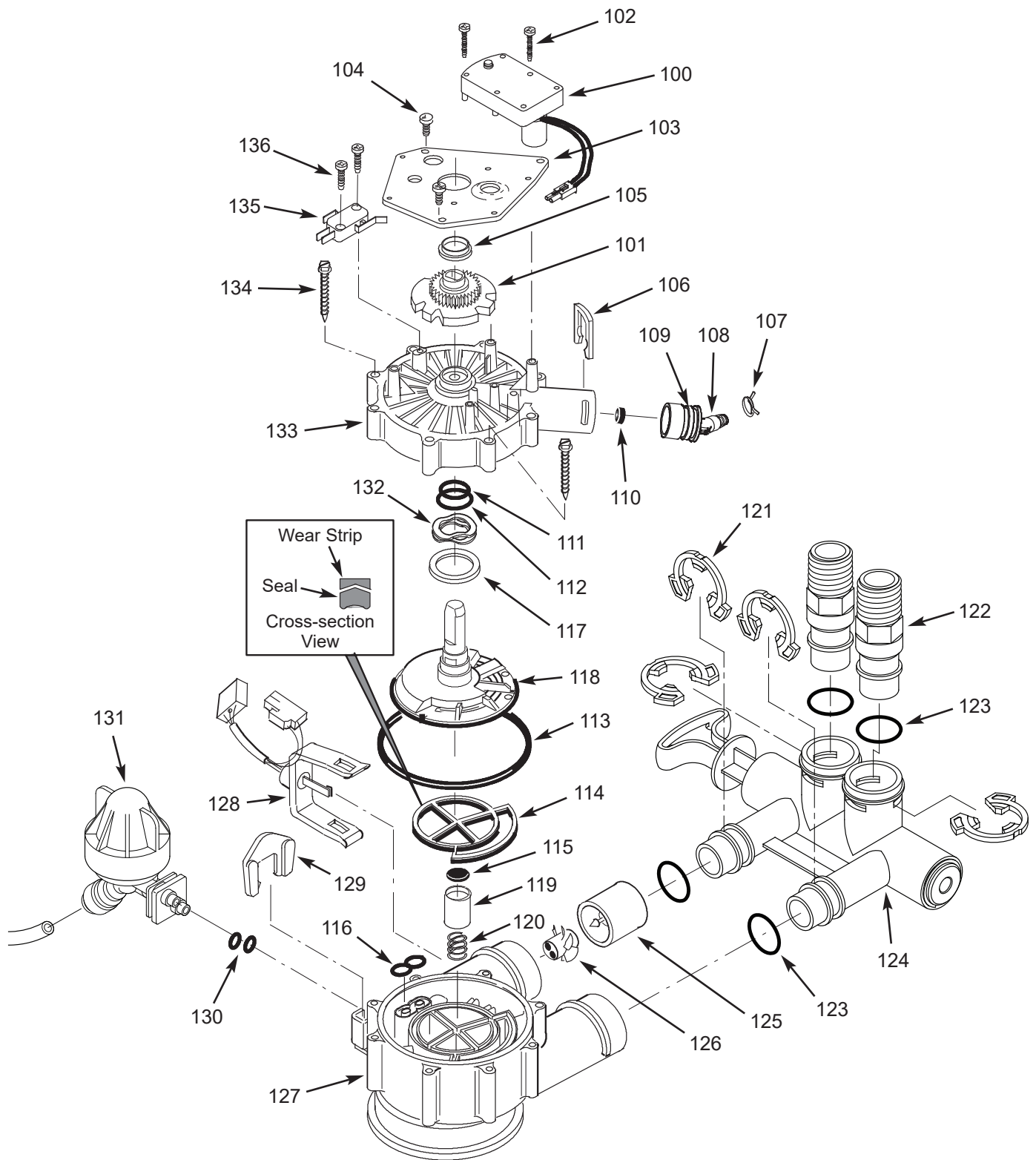

Valve Parts List

Key No.	Part No.	Description
–	7384691	Motor, Cam & Gear Kit, 1" (includes Key Nos. 100-102)
100	↑	Motor
101	↑	Cam & Gear
102	7224087	Screw, #8-32 x 1" (2 req.)
103	7231393	Motor Plate
104	0900857	Screw, #6-20 x 3/8" (3 req.)
105	7171250	Bearing
–	7331169	Drain Hose Adaptor Kit (includes Key Nos. 106-110)
106	↑	Clip, Drain
107	↑	Hose Clamp
108	↑	Drain Hose Adaptor
109	↑	O-Ring, 15/16" x 1-3/16"
110	↑	Flow Plug, 2.0 gpm
–	7185487	Seal Kit (includes Key Nos. 111-116)
111	↑	O-Ring, 5/8" x 13/16"
112	↑	O-Ring, 1-1/8" x 1-1/2"
113	↑	O-Ring, 4-1/2" x 4-7/8"
114	↑	Rotor Seal
115	↑	Seal
116	↑	Seal, Nozzle & Venturi
117	7174313	Bearing, Wave Washer
118	7185500	Rotor & Disc

Key No.	Part No.	Description
–	7342712	Drain Plug Kit, 1" (includes Key Nos. 115, 119 & 120)
119	↑	Plug, Drain Seal
120	↑	Spring
121	7337589	Clip, 1", pack of 4
122	7342704	Installation Adaptor, 1", pack of 2, including 2 ea. Clips & O-Rings (See Key Nos. 121 & 123)
123	7337597	O-Ring, 1-1/16" x 1-5/16", pack of 4
124	7214383	Bypass Valve Assembly, 1", including 2 ea. Clips & O-Rings (See Key Nos. 121 & 123)
–	7290931	Turbine & Support Assembly, including 2 O-Rings (See Key No. 123) & 1 ea. of Key Nos. 125 & 126
125	↑	Turbine Support & Shaft
126	↑	Turbine
127	7171145	Valve Body
128	7309811	Wire Harness, Sensor
–	7398705	Nozzle & Venturi Kit (includes Key Nos. 129-131)
129	↑	Retainer, Nozzle & Venturi
130	↑	O-Ring, 1/4" x 3/8" (2 pcs.)
131	↑	Nozzle & Venturi Assembly
132	7175199	Wave Washer
133	7171161	Valve Cover
134	7342681	Screw, #10-14 x 2-5/8", pack of 8
135	7305150	Switch
136	7140738	Screw, #4-24 x 3/4" (2 req.)

Questions? Visit www.kenmorewatersolutions.com or call 1-800-695-2761.

WARRANTY ON KENMORE® WATER SOFTENER

Warrantor: Water Channel Partners, 2805 Dodd Road, Suite 300, Eagan, MN 55121

Warrantor guarantees, to the original purchaser when the product is purchased from an authorized dealer, and when installed and maintained in accordance with the instructions, that:

One Year Full Warranty:

- For a period of one (1) year from the date the product is delivered, all parts will be free from defects in materials and workmanship and will perform in accordance with their written specifications.
- For a period of one (1) year from the date the product is delivered, labor to repair or replace any part determined by Warrantor to be defective in materials or workmanship, will be provided at no additional cost.

Limited Warranties:

- For a period of ten (10) years from the date the product is delivered, the salt storage tank and fiberglass resin/mineral tank will not rust, corrode, leak, burst, or in any other manner, fail to perform in accordance with their written specifications.
- For a period of three (3) years from the date the product is delivered, the electronic control board will be free of defects in materials and workmanship and will perform in accordance with its written specifications.

Proof of the date the product is delivered must be provided when making a warranty claim. If, during such respective period, a part proves to be defective, Warrantor will ship a replacement part, directly to your home, without charge. After the first year, labor necessary to maintain this product is not covered by the product warranty.

If you have questions regarding a warranted product, need assistance with installation or troubleshooting, wish to order a part or report a warranty issue, we are just a phone call away. SIMPLY DIAL 1-800-695-2761 for assistance.

General Provisions

The above warranties are effective provided the water softener is operated at water pressures not exceeding 125 psi (8.8 kg/cm²), and at water temperatures not exceeding 120°F (49°C); provided further that the water softener is not subject to abuse, misuse, alteration, neglect, freezing, accident or negligence; and provided further that the water softener is not damaged as the result of any force of nature such as, but not limited to, flood, hurricane, tornado or earthquake.

The limited warranty does not cover damage due to: (a) transportation, (b) storage, (c) improper use, (d) failure to follow the product instructions or to perform any preventive maintenance, (e) modifications, (f) unauthorized repair, (g) normal wear and tear, or (h) external causes such as accidents, abuse, or other actions or events beyond Warrantor's reasonable control. Use of aftermarket, used, or non-manufacturer provided parts will void all warranties. Warranty does not cover failures due to improper product installation. Warrantor is excused if failure to perform its warranty obligations is the result of strikes, government regulation, materials shortages, or other circumstances beyond its control.

THERE ARE NO WARRANTIES ON THE WATER SOFTENER BEYOND THOSE SPECIFICALLY DESCRIBED ABOVE. ALL IMPLIED WARRANTIES, INCLUDING ANY IMPLIED WARRANTY OF MERCHANTABILITY OR OF FITNESS FOR A PARTICULAR PURPOSE, ARE DISCLAIMED TO THE EXTENT THEY MIGHT EXTEND BEYOND THE ABOVE PERIODS. THE SOLE OBLIGATION OF WARRANTOR UNDER THESE WARRANTIES IS TO REPLACE OR REPAIR THE COMPONENT OR PART WHICH PROVES TO BE DEFECTIVE WITHIN THE SPECIFIED TIME PERIOD, AND WARRANTOR IS NOT LIABLE FOR CONSEQUENTIAL OR INCIDENTAL DAMAGES. NO DEALER, AGENT, REPRESENTATIVE, OR OTHER PERSON IS AUTHORIZED TO EXTEND OR EXPAND THE WARRANTIES EXPRESSLY DESCRIBED ABOVE.

Some states do not allow the exclusion or limitation of incidental or consequential damages, so the above limitation or exclusion may not apply to you. This warranty gives you specific legal rights, and you may have other rights which vary from state to state. This warranty applies to consumer-owned installations only.

**Manufactured under license by Water Channel Partners, Eagan, Minnesota.
Warranty provided by manufacturer.**